

OPERATING INSTRUCTIONS AND PARTS MANUAL

MODEL ZN-12

B TYPE

Decorative Nailer

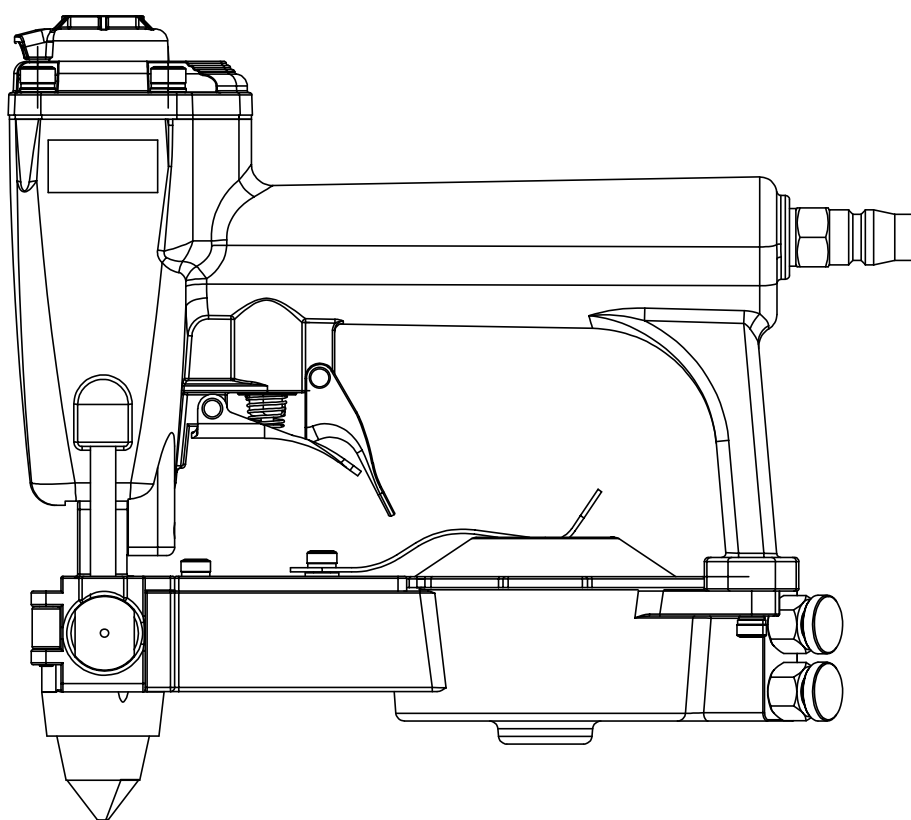

CAREFULLY READ THIS MANUAL BEFORE OPERATING TOOL

TOOL SPECIFICATIONS

MODEL OF TOOL	ZN-12		
TOOL LENGTH	9.84" (250 mm)		
TOOL HEIGHT	7.87" (200 mm)		
TOOL WIDTH	3.94" (100 mm)		
WEIGHT (WITHOUT FASTENERS)	2.43 lbs (1.1 kg)		
AIR INLET	1/4" NPT		
COMPRESSED AIR :			
Maximum permissible operating pressure	110 PSIG (7.5 bar)		
Recommended operating pressure range	65 - 90 PSIG (4.5 - 6 bar)		
AIR CONSUMPTION.....	0.245 scfm with 25 nails per minute @ 90 psi (6.2 bar)		

Noise dB(A) :

A-weighted sound pressure level LpA..... 80.52 dB(A)

A-weighted sound power level LwA..... 93.52 dB(A)

Measurement uncertainty: 3dB

Vibration (m/s²) :

Hand-arm vibration value..... 1.9 m/s²

Measurement uncertainty: 1.5 m/s²

Warning:

The vibration emission during actual use of the power tool can differ from the declared total value depending on the ways in which the tool is used; and of the need to identify safety measures to protect the operator that are based on an estimation of exposure in the actual conditions of use (taking account of all parts of the operation cycle such as the times when the tool is switched off and when it is running idle in addition to the trigger time).

List of fasteners for ZN-12BN :

Crown		Thickness		Width	MAGAZINE
9.5	11.6 mm	3.7	4.4 mm	1.4 mm	100 pcs
0.37	0.46 "	0.145	0.17 "	0.055 "	

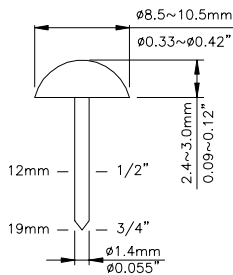

Foreword:

This pneumatic nailer is designed for using on soft material or driving tacks/decorative nails into wood. Its well balanced, ergonomic and comfort non-slip cushioned grip ensure you a satisfactory tackle and improve work efficiency. One of features is to drive different sizes of loose nails. No more painful hammering.

Suitable applications:

Leather upholstery, shoes, antique, trimming mattresses

Caution:

Staplers are only applying on wood. Not suitable for stapling or nailing into concrete, masonry bricks or steel. Do not fire if staples are jammed, as this will cause damage to the relevant parts.



Indicates an imminently hazardous situation which, if not avoided, will result in death or serious injury.

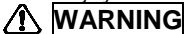

Indicates a potentially hazardous situation which, if not avoided, will result in death or serious injury.



Alerts the operator to useful information.

SAFETY INSTRUCTIONS



1. Read this manual and understand all safety instructions before operation the tool. If you have any questions, please contact our authorized representatives.
2. Only those fasteners listed in the operating instructions may be used in the fastener driving tools.
3. Only the main energy and the lubricants listed in the operating instructions may be used.
4. Fastener driving tools marked with an inverted equilateral triangle standing on one point may only be used with an effective safety yoke.
5. Fastener driving tools equipped with contact actuation or continuous contact actuation, marked with the symbol "Do not use on scaffoldings, ladders", shall not be used for specific application for example:
 - when changing one driving location to another involves the use of scaffoldings, stairs, ladders, or ladder alike constructions, e.g. roof laths,

closing boxes or crates,

fitting transportation safety systems e.g. on vehicles and wagons.

6. For the maintenance of fastener driving tools, only spare parts specified by the manufacturer or his authorized representative shall be used.
7. Repairs shall carried out by agents authorized by the manufacturer or by other specialists, having due regard to the information given in the operating instruction.
8. Stands for mounting the fastener driving tools to a support for example a work table shall be designed and constructed by the stand manufacturer in such a way that the fastener driving tool can be safely fixed for the intended use, thus for example avoiding damage, distortion or displacement.
9. Fastener driving tools operated by compressed air shall only be connected to compressed air lines where the maximum allowable pressure cannot be exceed by a factor of more than 10%, which can for example be achieved by a pressure reduction valve which includes a downstream safety valve.
10. When using fastener driving tools operated by compressed air, particular attention must be paid to avoid exceeding the maximum allowable pressure.
11. When using fastener driving tools operated by compressed air should only be operated at the lowest pressure required for the work process at hand, in order to prevent unnecessarily high noise levels, increased wear and resulting failures.
12. Hazards caused by fire and explosion when using oxygen or combustible gases for operating compressed air operated fastener driving tools.
13. Carry the fastener driving tool at workpiece using only the handgrip, and never with the trigger actuated. Never carry the tool by the hose or pull the hose to move the tool.

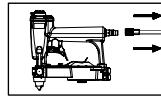

14. Disconnect the tool from air supply before cleaning jams, servicing, adjusting, and during non-operation.



15. Wear eye protection.

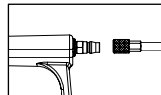

16. Do not use a check valve or any other fitting which allows air to remain in the tool.



17. Do not place your hand or any part of your body in the fastener discharge area of the tool when connecting or disconnecting air supply.



18. Never point tool at yourself or at any other person.

AIR SUPPLY AND CONNECTION



Many air tool users find it convenient to use oiler to help provide oil circulation through tool and increase the efficiency and useful life of the tool. Check oil level in the oiler daily.

Many air tool user find it convenient to use a filter to remove liquid and impurities which can rust or wear internal parts of the tool. A filter also increase the efficiency and useful of the tool. The filter must be checked on a daily basis and if necessary drained. For better performance, install a 3/8" quick connector (1/4" NPT threads) with an inside diameter of .315" on your tool and a 3/8" quick coupler on the air hose.

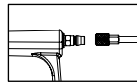
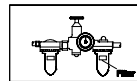
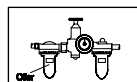

The following illustration shows the correct mode of connection to the air supply system which will increase the efficiency and useful life of the tool.

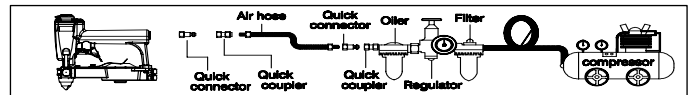

LUBRICATION AND MAINTENANCE



Disconnect the air supply from the tool before lubricating.

Your tool requires lubrication before you use it for the first time.

Wipe off excessive oil at the exhaust. Excessive oil will damage O-rings of tool. If in-line oiler is used, manual lubrication through the air inlet is not required on a daily basis.

Turn the tool so the inlet is facing up and put one drop of high speed spindle oil, UNOCAL RX22, or 3-IN-1 oil into air inlet. Never use detergent oil or additives. Operate the tool briefly after adding oil.

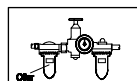
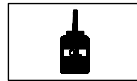
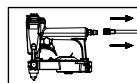

LOADING THE TOOL

⚠ WARNING



Do not place your hand or any part of your body in the fastener discharge area of the tool when connecting or disconnecting air supply.

⚠ WARNING



Never point any operational fastener driving tool at yourself or at any other person.

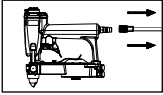

1. Disconnect air hose.

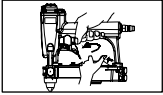

2. Open the cover clip and remove the chute cover (1)

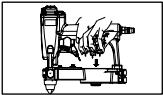

3. Place a handful of nails into the front case. The front case capacity is 100 nails.

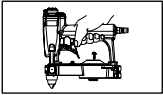

4. Put the chute cover back and make sure the cover clip is in position against the feed channel.

OPERATING THE TOOL

⚠ WARNING



Protect your eyes and ears. Wear z87.1 safety glasses with side shields. Wear hearing protection. Employers and users are responsible for ensuring the user or anyone near the tool wear this safety protection.

⚠ NOTE

Check and replace any damaged or worn components on the tool. The safety warning labels on the tool must also be replaced if they are not legible.



Fig.1

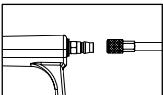

Fig.2

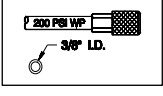

Fig.3

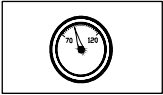

Fig.4

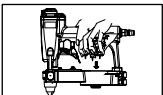

Fig.5

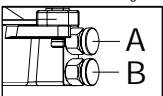

Fig.6

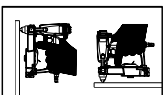

Fig.7

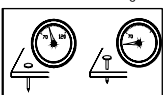
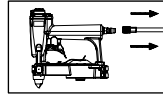

Fig.8

- Add a few drops of UNOCAL RX22 or 3-in-1 oil into the air inlet. (See Fig. 1)
- Attach a high flow quick connect fitting to the tool. (See Fig. 2)
- Empty the magazine.
- Connect the tool to an air compressor using a 3/8" I.D hose. Make sure the hose has a rated working pressure exceeding 200 PSI (13.8bar) and a female quick coupler. (See Fig. 3)
- Regulate the air pressure to obtain 90-100 PSI (4.8 bar) at the tool. (See Fig. 4)
- Disconnect the air supply from the tool.
- Load fasteners into your tool following the instructions in this manual. (See Fig. 5)
- Reconnect the air supply to the tool.
- A: Start the nails rotating in the front case by opening air valves. Blow nails to feed channel. Adjust the speed of rotation according to nails quantity.
B: Blow nails upon top. Adjust the speed of rotation according to nails quantity. (See Fig. 6)
- The first shot will be blank if the gun has been cleared. To clear the gun after use turn off air valves and pull trigger once to clear the firing chamber. The gun is used in the horizontal or vertical position. (See Fig. 7)
- Test for proper fastener penetration by driving nails into a sample piece of wood. If the fasteners do not achieve the desired penetration, adjust the air pressure to a higher setting until the desired penetration is achieved. Do not exceed 110 PSI (7.6 bar) at the tool. (See Fig. 8)

CLEARING A JAM FROM THE TOOL

⚠ WARNING



Disconnect the tool from air compressor before adjusting, clearing jams, servicing, relocating and during non-operation.

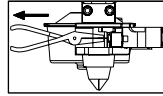

- Fastener jammed in fastener discharge area:
Disconnect tool from air hose.
Grab jammed fastener with pliers and remove.

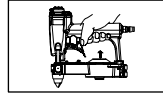

- Fastener jam inside magazine:
Disconnect air tool from air hose.
Pull back on fastener pusher until locked.
Removed jammed fastener.
Release fastener pusher.

CLEANING THE TOOL

⚠ DANGER



Never use gasoline or other flammable liquids to clean the tool. Vapors in the tool will ignite by a spark and cause the tool to explode and result in death or serious personal injury.

⚠ NOTE

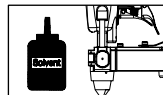

Solvents used to clean the nose of the tool and contact safety trip mechanism may soften the tar on the shingles and cause the buildup to be accelerated. Make sure to dry the tool thoroughly after cleaning and before operating the tool again.

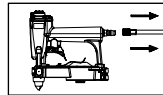

- Disconnect the air supply from the tool.

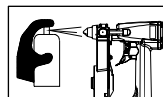

- Remove tar buildup with kerosene #2 fuel oil or diesel fuel. Do not allow solvent to get into the cylinder or damage may occur. Dry off the tool completely before use.

TROUBLESHOOTING

Stop using the tool immediately if any of the following problems occur. Serious personal injury could. Any repairs or replacements must be done by a qualified person or an authorized service center only.

PROBLEM	PROBABLE CAUSE	REMEDY
Air leaking at trigger valve area.	O-rings in trigger valve housing are damaged.	O-rings must be replaced.
Air leaking between housing and nose.	Loose screws in housing. Damaged to bumper.	Screws need to be tightened. O-rings must be replaced.
Air leaking between housing and cap Assy.	Damage to bumper. Loose screws. Damaged seal.	Bumper needs to be tightened. Screws need to be tightened. Seal needs to be replaced.
Tool skips driving fastener.	Worn bumper. Dirt in nose. Dirt or damage prevents fasteners from moving freely in magazine. Inadequate air flow to tool. Worn O-ring on piston or lack of lubrication. Damaged O-rings on trigger valve. Air leaks. Cap seal leaking.	Bumper needs to be replaced. Clean. Magazine needs to be cleaned. Fitting hose or air compressor needs to be checked. O-ring needs to be replaced. Lubricate. O-rings need to be replaced. Screws and fittings need to be tightened. Seal needs to be replaced.
Tool runs slow or has loss of power.	Tool not lubricated sufficiently. Broken spring in cap Assy. Exhaust port in cap is blocked.	Tools needs to be lubricated. Spring needs to be replaced. Damaged internal parts need to be replaced.
Fasteners are jammed in tool.	Driver nozzle worn or damaged. Driver is damaged. Fasteners are not correct size. Fasteners are bent. Magazine or nose screws are loose.	Replace driver nozzle. Replace driver. Fasteners recommended for tool must be used. Replace with undamaged fastener. Screws need to be tightened.

ZN-12BA02N (WO/A1-02N)

a

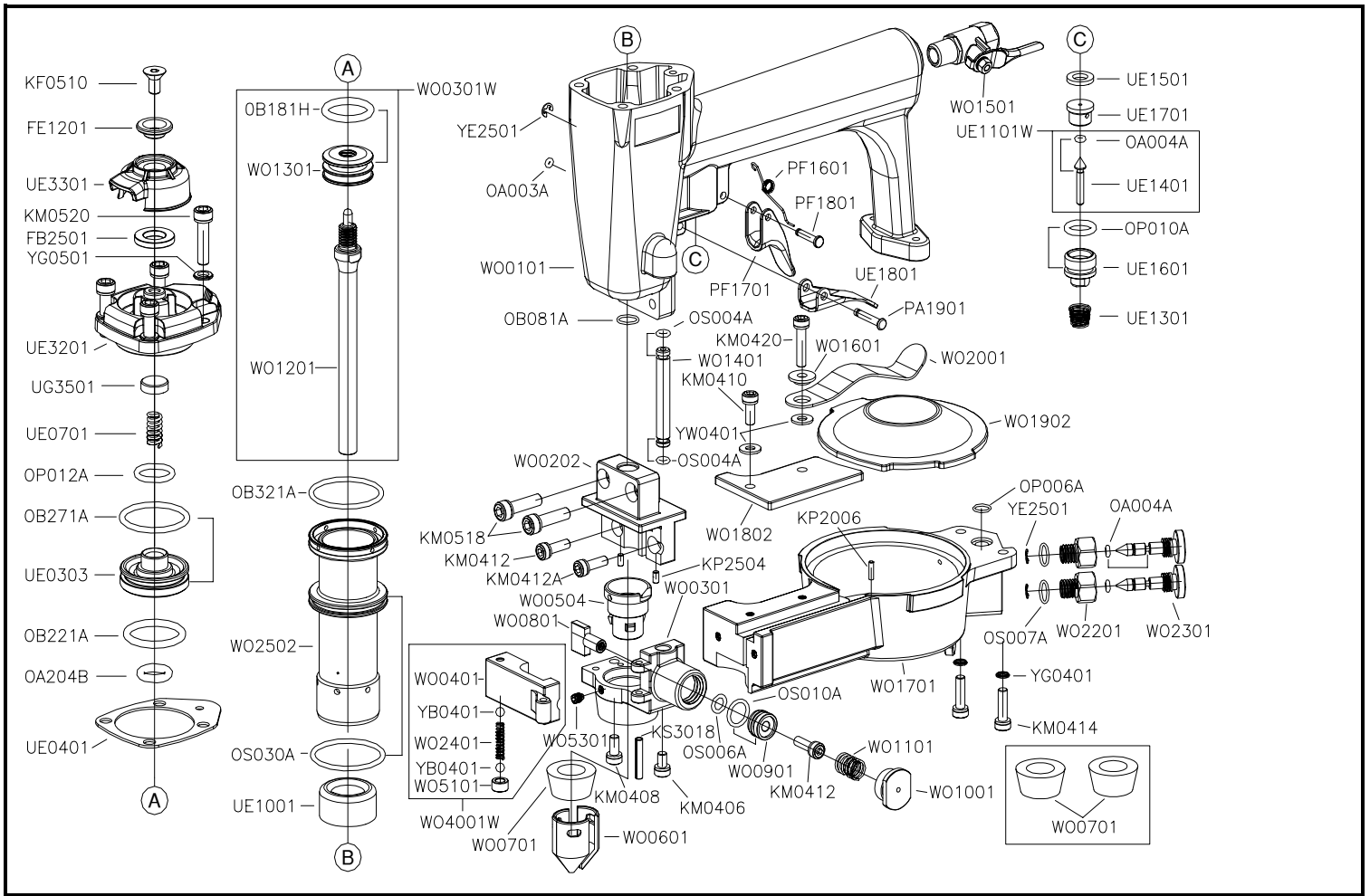

Part_No	Description	Spec	Q'ty	Part_No	Description	Spec	Q'ty	Part_No	Description	Spec	Q'ty
FB2501	PISTON STOP		1	OS030A	O-RING	S-30	1	WO1101	COMPRESSION SPRING		1
FE1201	EXHAUST CAP RING		1	PA1901	PIN		1	WO1201	DRIVER		1
KF0510	FLAT HD.BOLT	M5×0.8 - 10L	1	PF1601	SPRING		1	WO1301	MAIN PISTON		1
KM0406	HEX.SOC.HD.BOLT	M4×0.7 - 6L	1	PF1701	SAFETY LEVER		1	WO1401	AIR PIPE		1
KM0408	HEX.SOC.HD.BOLT	M4×0.7 - 8L	1	PF1801	PIN		1	WO1501	COCK		1
KM0410	HEX.SOC.HD.BOLT	M4×0.7 - 10L	1	UE0303	HEAD VALVE PISTON		1	WO1601	SCREW SEAT		1
KM0412	HEX.SOC.HD.BOLT	M4×0.7 - 12L	2	UE0401	CAP SEAL		1	WO1701	FRONT CASE		1
KM0412A	HEX.SOC.HD.BOLT	M4×0.7 - 12L	1	UE0701	COMPRESSION SPRING		1	WO1802	CHUTE COVER(2)		1
KM0414	HEX.SOC.HD.BOLT	M4×0.7 - 14L	2	UE1001	BUMPER		1	WO1902	CHUTE COVER(1)		1
KM0420	HEX.SOC.HD.BOLT	M4×0.7 - 20L	1	UE1101W	TRIGGER VALVE ASSY.		1	WO2001	COVER CLIP		1
KM0518	HEX.SOC.HD.BOLT	M5×0.8 - 18L	2	UE1301	COMPRESSION SPRING		1	WO2201	HOPPER VALVE		2
KM0520	HEX.SOC.HD.BOLT	M5×0.8 - 20L	4	UE1401	TRIGGER VALVE STEM		1	WO2301	AIR VALVE		2
KP2006	PARALLEL PIN	2×6L	1	UE1501	SEAL		1	WO2401	COMPRESSION SPRING		1
KP2504	PARALLEL PIN	2.5×4L	2	UE1601	TRIGGER VALVE GUIDE		1	WO2502	CYLINDER		1
KS3018	SPRING PIN	3-18L	1	UE1701	TRIGGER VALVE SEAT		1	WO4001W	DOOR CATCH ASSY.		1
OA003A	O-RING	ARP568-003	1	UE1801	TRIGGER		1	WO5101	TUBE		1
OA004A	O-RING	ARP568-004	3	UE3201	CYLINDER CAP		1	WO5301	SHAFT		1
OA204B	O-RING	ARP568-204	1	UE3301	EXHAUST CAP		1	YB0401	STEEL BALL	4	2
OB081A	O-RING	8×1	1	UG3501	PISTON STOP		1	YE2501	E-RING	2.5	3
OB181H	O-RING	17.7×3.0	1	WO0101	BODY		1	YG0401	SPRING WASHER	4	2
OB221A	O-RING	22×3	1	WO0202	NAIL SEAT		1	YG0501	SPRING WASHER	5	4
OB271A	O-RING	26.8×2.4	1	WO0301	FEED SEAT		1	YW0401	FLAT WASHER	4	2
OB321A	O-RING	32×1	1	WO0301W	DRIVER ASSY.		1				
OP006A	O-RING	P6	1	WO0401	DOOR CATCH		1				
OP010A	O-RING	P10	1	WO0504	COLLET BODY		1				
OP012A	O-RING	P12	1	WO0601	COLLET WINGS		3				
OS004A	O-RING	S-4	2	WO0701	NOZZLE RUBBER		3				
OS006A	O-RING	S-6	1	WO0801	PIN PUSHER		1				
OS007A	O-RING	S-7	2	WO0901	CUP SEAL		1				
OS010A	O-RING	S-10	1	WO1001	END CAP		1				

If you need to order parts, please mark both Parts No. and Description.